

ROME

MUSEUM EXHIBITION

INTERNATIONAL
FAIR
ON MUSEUMS, VENUES
AND CULTURAL DESTINATIONS

15-17

November 2023

6th edition - Fiera Roma

EXHIBITOR KIT

powered by



certified by



157/2022
RMSX22RS1

OFFER A

Fitted Booth (from 16sqm)

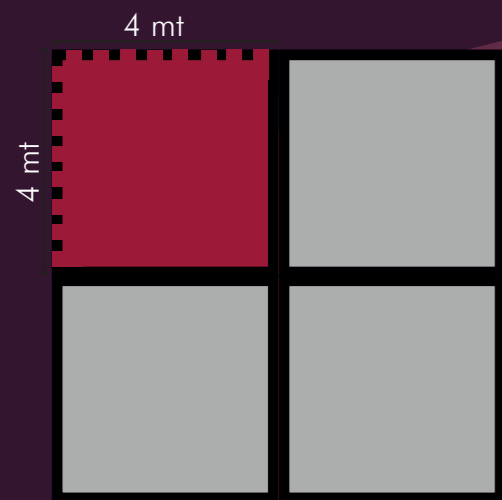

4x4 (16 sqm): € 3.800,00+VAT

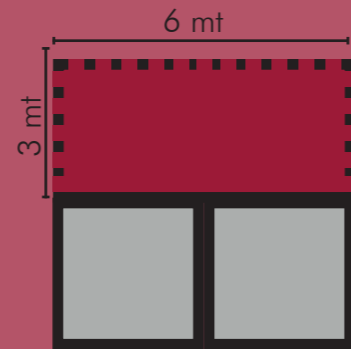

6x3 (18 sqm): € 4.220,00+VAT

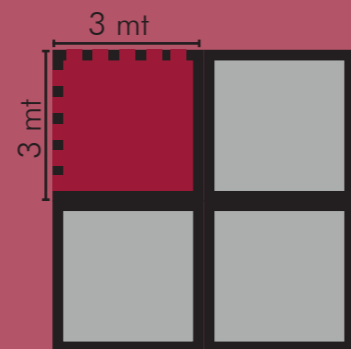

3x3 (9 sqm): € 2.330,00+VAT

Fitted Booth 3x3
(exclusive for Publishers,
Start Up, University and
Training Institutions)

TECNICAL CHARACTERISTIC:

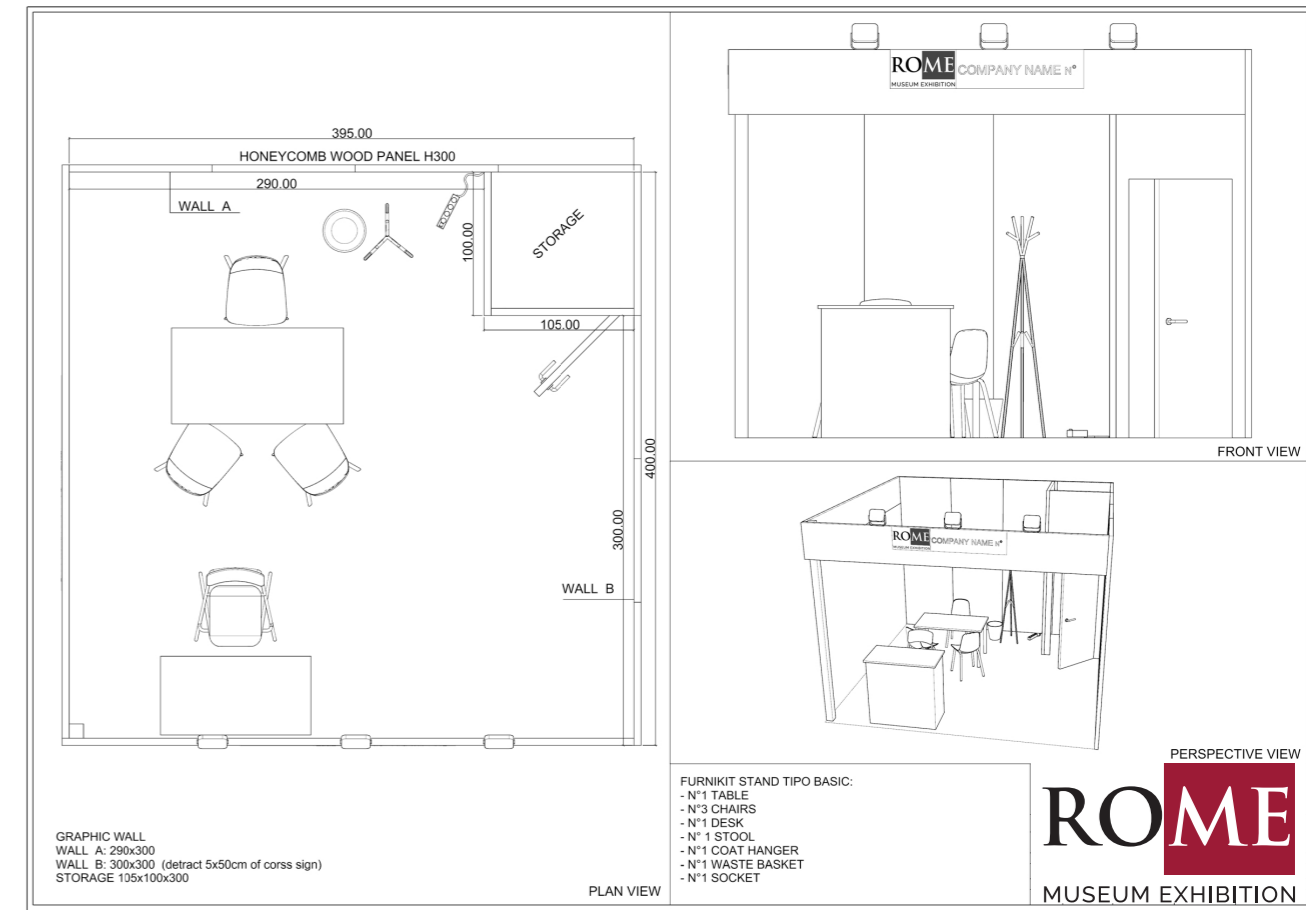

THE QUOTATION INCLUDES:



Registration fee;
Basic insurance coverage RCT-RCO; technical
inspection for stand assembly and testing;



Corner fitted booth, perimeter wall paneling in
honeycomb wood, booth sign with company
name, storage;



Furniture kit with n.1 table, n.3 chair, n.1 desk, n.1
stool, n.1 waste basket and n.1 coat hanger;



1 fire extinguisher



2kw electricity supply;
1 power socket;



Electrical installation with spot-
light 100 watt



Moquette



3 exhibitors pass of 9sqm
4 exhibitors pass of 16 and 18sqm



1 pass auto to internal parking space



Marketplace (online product showcase engage attendees
with detailed product descriptions through multimedia contents
provided by the exhibitor www.romemuseumexhibition.com)



B2B Sessions
(schedule one-to-one appointments with buyer
and exhibitors)



Inclusion in the catalogue and in the official
information materials of the event



WI-FI Free

OFFER B

Area Only (FROM 36sqm):

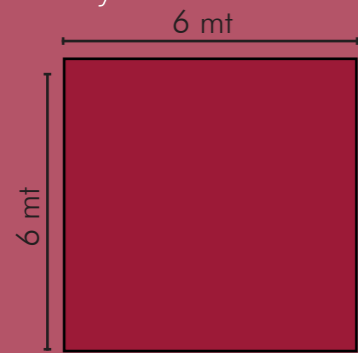

€ 170,00/sqm +VAT

THE QUOTATION (AREA ONLY + REGISTRATION FEE AND ELECTRICITY SUPPLY) INCLUDES:



Registration fee;
Basic insurance coverage RCT-RCO; technical inspection for stand assembly and testing;



6 exhibition pass of 36sqm



2kw electricity supply;



1 pass auto to internal parking space



1 fire extinguisher



B2B Sessions
(schedule one-to-one appointments with buyer and exhibitors)

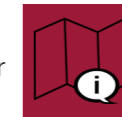

Inclusion in the catalogue and in the official information materials of the event



Marketplace (online product showcase engage attendees with detailed product descriptions through multimedia contents provided by the exhibitor www.romemuseumexhibition.com)



WI-FI Free

COMPLETE YOUR PARTICIPATION WITH

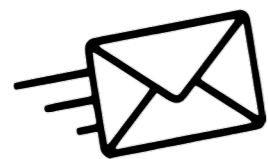

ADVERTISING Newsletter dedicated*

N.1 sending to the database of
ROME Museum Exhibition
€ 1.000,00 +VAT

Advertising page* in the official catalogue of the event



Full page € 800,00 +VAT
1/2 Page € 500,00 +VAT

WELCOME EVENT

Entrance pass for the **opening event** (exclusive for exhibitors)



€ 120,00 +VAT/1 pax



Insertion of **information material*** in the Official Shopper of the event

€ 800,00 +VAT

HANDS ON SESSION Slot self-organized of 30'

€ 1.000,00 +IVA



ROME | **15-17**
MUSEUM EXHIBITION | November 2023

INFORMATION | EXHIBIT | B2B |
SPONSORSHIP | CORPORATE EVENTS:
commerciale@romemuseumexhibition.com



romemuseumexhibition.com

powered by



certified by



157/2022
RMSX22RS1